



HOW SECURE IS MY HOME?

There are many elements that contribute to home security. Some – like alarm systems – can be expensive. Security doors can create a sense of living in an armed camp, instead of a neighborhood. They may even foster a false sense of security – windows, especially those at the rear of a house, can be equally vulnerable as doors. On the other hand, there are many strategies that can increase your safety without compromising the attractiveness of your home or emptying your pocketbook.

Lighting:

Visibility is your first defense against intruders. You might consider connecting an exterior light to a motion sensor. At a minimum, switch on exterior lights in the front and back of your home – and at least one light on the inside – whenever you leave the house. If your house is hidden by bushes, cut them back. Landscape lighting can beautify your home’s exterior while adding security.

Doors and Windows:

The composition and design of your exterior doors affects how well they protect against intruders. A hollow wood door is most susceptible; a door with a solid wood core or one made of metal is much more resistant. Windows in an exterior entry door, or next to it, should be sized and located so that access to the door lock cannot be gained by breaking the glass.

Equally important are the types of locks on your doors and windows. Deadbolt locks provide much more security than the traditional spring lock in the doorknob. However, make sure the model you choose allows for easy exit in case of fire. (You don’t want to be searching through a smoky room for a key that has fallen somewhere on the floor.) Install a heavy-duty strike plate, with four screws; it will be stronger than the more common two-screw variety. And, for the deadbolt to be effective, make sure that the screws for the strike plate and at least one screw per hinge are long enough to go through the door jamb and into the rough framing (*see Illustration 1*).

Metal “wrought-iron look” security doors are *not recommended* by most fire departments – including Cleveland Heights’ – due to the difficulty of fire personnel gaining entry to the home in an emergency. (Many security doors don’t allow for any ventilation in the summer, either.)

Windows are more secure with two standard locks on each window, or a better quality system. Nails inserted into holes drilled through the lower sash and into the upper sash will give extra security (*see Illustration 2*); you can drill additional holes in the upper sash to allow the window to be locked in an open position.

Alarm Systems:

If your “risk analysis” indicates that you would benefit from an alarm system, make sure you check out thoroughly the credentials of the company selling and installing the equipment. With some systems, an alarm sounds and/or lights go on; other systems will automatically dial the local

(continued)

police department when the alarm is triggered. Make sure you know whether the system you're considering has any ongoing costs after the initial purchase and installation of the equipment.

Personal Habits:

Even the best designed system cannot provide security if the homeowners do not take some common sense precautions in their daily life. Never leave a key outside, no matter how ingenious you think your hiding spot is – burglars know them all. Inform the police if you'll be away, so they know to watch for unusual happenings. Have someone pick up your mail, papers, and trash, and in winter, drive into your snow-covered driveway, so it isn't evident the house is vacant. And, agree with your neighbors to watch out for one another—either informally, or through an organized “block watch.”

Finally, you might decide that a dog would be a good addition to your household.....

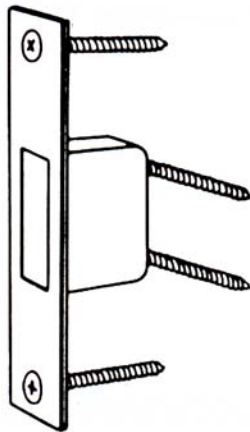
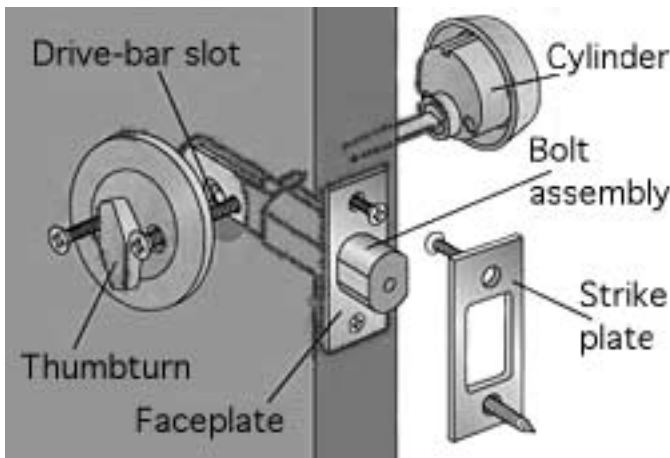

Heavy-duty strike plate

Illustration 1

SIMPLE WINDOW LOCKS THAT WORK
 Use large double-headed nails ("scaffolding nails").

- ① Lock sash lock to pull upper & lower together
- ② Mark location for hole well in from all edges. Choose drill bit slightly larger than nail thickness
- ③ Drill at slight downward angle thru lower sash & well into, but not thru upper sash.

©1987-Housing Resource Center



Window lock and Keeper

Illustration 2